

PHILIP

MACHINE CO.

METAL PRODUCTS MANUFACTURER

**184 Woonasquatucket Avenue
North Providence, Rhode Island 02911
(401)-353-7383 • FAX (401)-353-8430
www.philipmachine.com**

DOUBLE BARS

.080 LIQUOR FINISH STEEL

ITEM NO.
SIZE



#1016
1"

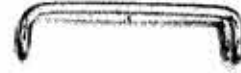

#1010
1-1/4"



#1014
1-1/2"



#1033
1-3/4"



#1034
2"



#1077
2-1/4"

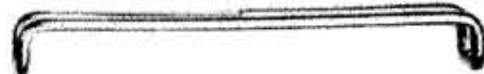

#1043
2-1/2"

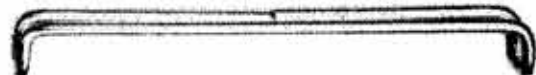

PHILIP MACHINE COMPANY

184 WOONASQUATUCKET AVENUE NORTH PROVIDENCE, RHODE ISLAND 02911

DOUBLE BARS

(ASSORTED)



1 1/2" x .060 DOUBLE BAR - #1171



2" x 1/2" x .050 Adjustor - #1175



3" x .090 DOUBLE BAR - #1176



WELDED BELT EYE/DOUBLE BAR
Adjustor
(AVAILABLE BRASS/NICKEL)

- 3/4" - #1202
- 1" - #1183
- 1 1/4" - #1184
- 1 1/2" - #1185
- 1 3/4" - #1203
- 2" - #1186



HiLo DOUBLE BARS .080









- 1" - #1023
- 1 1/4" - #1017
- 1 1/2" - #1204
- 1 3/4" - #1201
- 2" - #1205
- 2 1/4" - #1206
- 2 1/2" - #1207

PHILIP MACHINE COMPANY

184 WOONASQUATUCKET AVENUE NORTH PROVIDENCE, RHODE ISLAND 02911

DOUBLE BARS

.060 LIQUOR FINISH STEEL



| SHORT | | ITEM NO. SIZE | TALL | | ITEM NO. SIZE |
|---|--|------------------|---|--|------------------|
|  | | #1008 1/2" |  | | #1005 1/2" |
|  | | #1009 3/4" |  | | #1046 3/4" |
|  | | #1006 1" |  | | #1056 1" |
|  | | #1007 1 1/4" |  | | #1049 1 1/4" |

PHILIP MACHINE COMPANY

184 WOONASQUATUCKET AVENUE NORTH PROVIDENCE, RHODE ISLAND 02911

SINGLE BARS

.080 LIQUOR FINISH STEEL

| | ITEM NO. SIZE |
|---|------------------|
|  | #1188 1/2" |
|  | #1163 3/4" |
|  | #1164 1" |
|  | #1189 1 1/4" |
|  | #1190 1 1/2" |
|  | #1191 1 3/4" |
|  | #1192 2" |

PHILIP MACHINE COMPANY

184 WOONASQUATUCKET AVENUE NORTH PROVIDENCE, RHODE ISLAND 02911

HOOKS AND EYES

COMPLETE BUCKLE

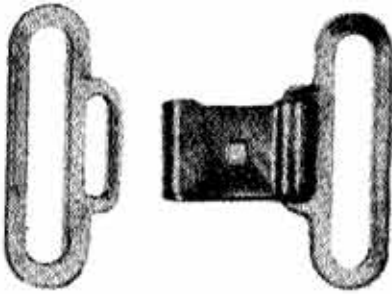

| <u>EYE SIZE</u> | <u>ASSEMBLED HOOK & EYE</u> | <u>ASSEMBLED HOOK & EYE WITH ACETATE PAD</u> | <u>EYE ONLY</u> |
|-----------------|---------------------------------|--|-----------------|
| 3/4" | #HE59115 | #HEA59115 | #1115 |
| 1 | HE59112 | HEA59112 | 1112 |
| 1 1/4 | HE59111 | HEA59111 | 1111 |
| 1 1/2 | HE59110 | HEA59110 | 1110 |
| 1 3/4 | HE59101 | HEA59101 | 1101 |
| 2 | HE59133 | HEA59133 | 1133 |

COMPLETE BUCKLE

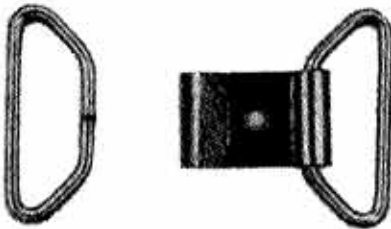

| <u>EYE SIZE</u> | <u>ASSEMBLED HOOK & EYE</u> | <u>ASSEMBLED HOOK & EYE WITH ACETATE PAD</u> | <u>EYE ONLY</u> |
|-----------------|---------------------------------|--|-----------------|
| 1/2" | #HE59021 | #HEA59021 | #1021 |
| 3/4 | HE59027 | HEA59027 | 1027 |
| 1 | HE59026 | HEA59026 | 1026 |

COMPLETE BUCKLE

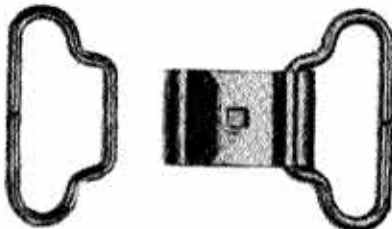

| <u>EYE SIZE</u> | <u>ASSEMBLED HOOK & EYE</u> | <u>ASSEMBLED HOOK & EYE WITH ACETATE PAD</u> | <u>EYE ONLY</u> |
|-----------------|---------------------------------|--|-----------------|
| 1" | #HE59109 | #HEA59109 | #1109 |
| 3 | HE59030 | HEA59030 | 1030 |

ACETATE PAD



| <u>SIZE</u> | <u>STOCK #</u> |
|-------------|----------------|
| 1/2" | #1173 |

- HOOK AVAILABLE WITH .095 / .128 ROUND OR SQUARE HOLE
- ITEMS ASSEMBLED AND PLATED TO MEET YOUR NEEDS
- HOOK & EYE ASSEMBLY AVAILABLE WITH ACETATE PAD FOR GLUING

PHILIP MACHINE COMPANY

184 WOONASQUATUCKET AVENUE NORTH PROVIDENCE, RHODE ISLAND 02911

HOOKS AND EYES



3/16" SINGLE HOOK
-SHORT

COPPER-#1036



3/16" SINGLE HOOK
-LONG

COPPER-#1038



1/4" SINGLE HOOK
-SHORT

COPPER-#1071



1/4" SINGLE HOOK
-LONG

* COPPER-#1037
* STEEL- 1094



1/2" SINGLE HOOK

* STEEL-1095
* BRASS-1080



1/2" SINGLE HOOK

COPPER-#1098
STEEL- 1099
BRASS-1097



1/2" SINGLE HOOK
-LONG

* COPPER-#1093
* STEEL-1091
* BRASS-1092



3/16" FLAT SINGLE HOOK

STEEL-#1129



3/16" DOUBLE HOOK
-SHORT

*COPPER-#1088
*STEEL- 1089
*BRASS- 1090



3/16" DOUBLE HOOK
-LONG

*COPPER-#1074
*STEEL- 1075



1/2" DOUBLE HOOK

*COPPER-#1166
*STEEL-1159



1/2" DOUBLE HOOK

*STEEL-#1174



1/2" DOUBLE HOOK
-LARGE

STEEL-#1177



5/8" FLAT DOUBLE HOOK

STEEL-#1130



1/2" BUCKLE EYE

COPPER-#1104



1/4" BUCKLE EYE

COPPER-#1187

NOTE: COPPER = COPPER COATED STEEL, BRASS = SOLID BRASS, STEEL = BARE STEEL
* AVAILABLE WITH .095 HOLE

PHILIP MACHINE COMPANY

184 WOONASQUATUCKET AVENUE NORTH PROVIDENCE, RHODE ISLAND 02911

HOOKS AND EYES



#1235



#1198



#1304



#1258



#1130



#1129



#1217



#1255



#1281



#1307



#1308



#1310



#1309

PHILIP MACHINE COMPANY

184 WOONASQUATUCKET AVENUE NORTH PROVIDENCE, RHODE ISLAND 02911

CONNECTORS



#1216



#1261



#1155



#1289



#1234



#1196



#1279



#1246



#1253



#1156



#1161



#1230



#1054



#1073



#1214



#1299

PHILIP MACHINE COMPANY

184 WOONASQUATUCKET AVENUE NORTH PROVIDENCE, RHODE ISLAND 02911

SLIDES



#1256- $\frac{3}{4}$ "



#1265-1"



#1266-1- $\frac{1}{4}$ "



#1267-1- $\frac{1}{2}$ "



#1268-1- $\frac{3}{4}$ "



#1269-2"

PHILIP MACHINE COMPANY

184 WOONASQUATUCKET AVENUE NORTH PROVIDENCE, RHODE ISLAND 02911

BELT EYES

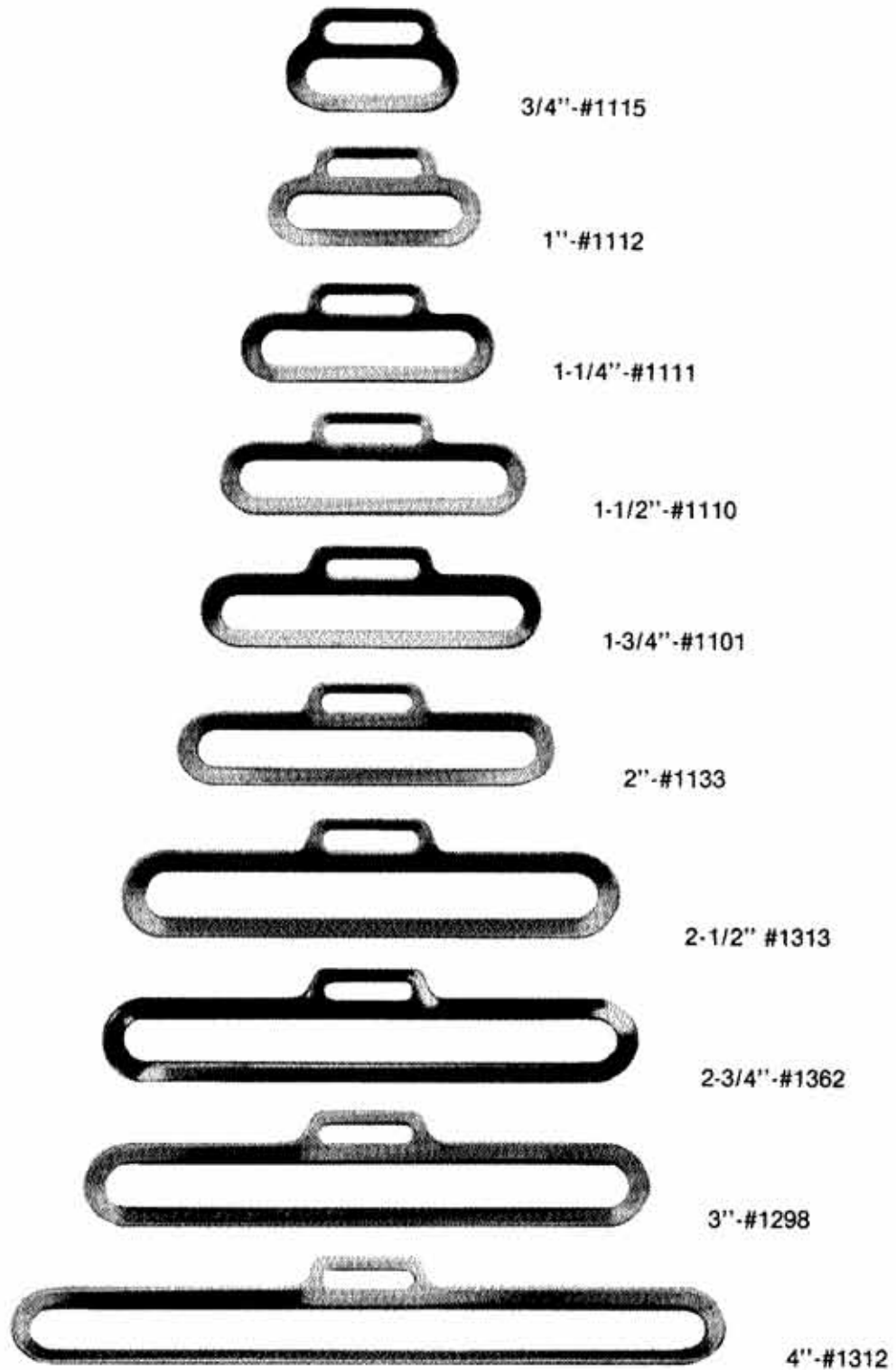

PHILIP MACHINE COMPANY

184 WOONASQUATUCKET AVENUE NORTH PROVIDENCE, RHODE ISLAND 02911

HOOKS/CONNECTORS/STAPLES



1504



1531

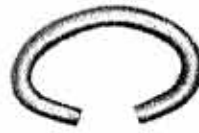

1498



1460



1444



1486



1439



1346



1432



1324



1462



1446



1373



1365



1395



1356



1466

PHILIP MACHINE COMPANY

184 WOODNASQUATUCKET AVENUE NORTH PROVIDENCE, RHODE ISLAND 02911

"D" & "O" RINGS



#1065-(11/32 x .060)



#1031-(1/4 x 3/16 x .050)



#1022-(9/16 x 7/16 x .080)



#1131-(11/16 x 3/16 x .080)



#1172-(5/16 x 11/32 x .070)



#1070-(5/8 x 7/16 x .090)



#1025-(9/16 x 5/16 x .102)



#1013-(9/16 x 9/32 x .070)



#1035-(1 x 3/8 x 102)

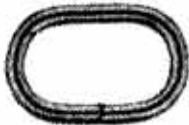

#1106-(3/4 x 3/8 x 128)



#1047-(1/2 x 7/16 x .070)



#1193-(3/4 x 3/4 x 128)



#1069-(5/8 x .090)



#1146-(1/2 x 5/16 x .080)



#1154-(5/8 x 5/16 x 102)



#1018-(1/2 x 3/8 x .080)



#1060-(3/4 x 3/8 x 128)



#1116-(3/4 x 1/2 x 102)

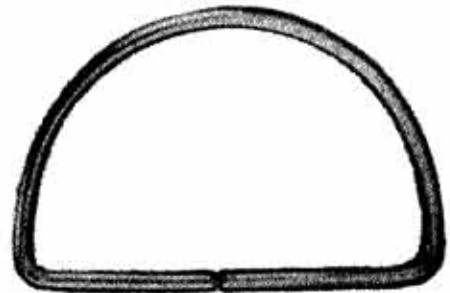

#1180-(2 x 1 1/4 x .128)

PHILIP MACHINE COMPANY

184 WOONASQUATUCKET AVENUE NORTH PROVIDENCE, RHODE ISLAND 02911

"D" RINGS



#1286-(7/16x.080)



#1292-(5/8x.120)

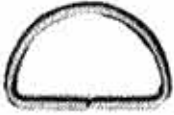

#1211-(3/4x.080)



#1197-(3/4x.114)



#1318-(3x.220)

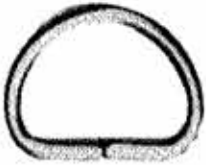

#1293-(7/8x.135)

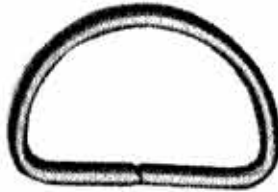

#1238-(1-1/4x.128)



#1218-(1x.128)

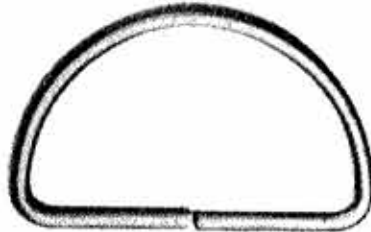

#1236-(1-3/4x.128)

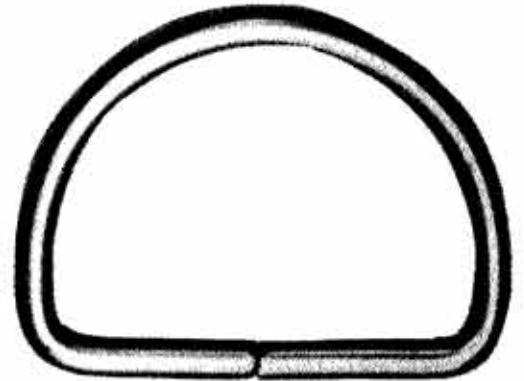

#1291-(2x.190)

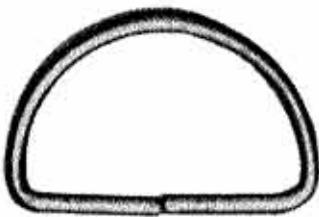

#1237-(1-1/2x.128)



#1294-(1-1/2x.120)

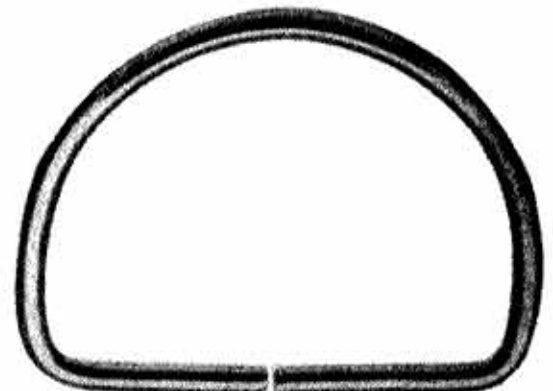

#1222-(2-1/4x.220)

PHILIP MACHINE COMPANY

184 WOONASQUATUCKET AVENUE NORTH PROVIDENCE, RHODE ISLAND 02911

"O" RINGS



#1250-(3/8x.060)



#1221-(3/8x.080)



#1252-(1/2x.090)



#1287-(1/2x.080)



#1329-(3/4x.114)



#1311-(3/4x.090)



#1338-(7/8x.102)



#1275-(1x.102)



#1264-(1x.128)

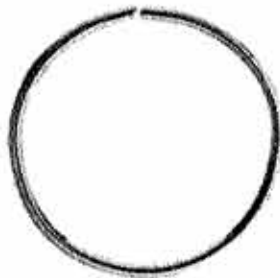

#1282-(1-1/4x.102)



#1277-(1-1/4x.128)



#1195-(1-1/2x.128)



#1303-(2-3/4x.220)

PHILIP MACHINE COMPANY

184 WOONASQUATUCKET AVENUE NORTH PROVIDENCE, RHODE ISLAND 02911

OVAL RINGS



#1280-(3/4x5/16x.102)

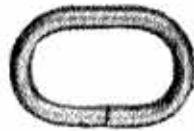

#1106-(3/4x3/8x.128)



#1326-(11/16x1/4x.114)



#1220-(1/2x7/64x.090)



#1320-(3/4x1/4x.070)



#1231-(3/4x3/16x.070)

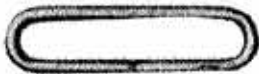

#1249-(1-1/4x1/4x.080)

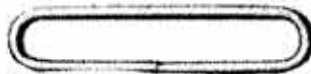

#1248-(1-1/2x1/4x.080)



#1305-(1x3/16x.080)

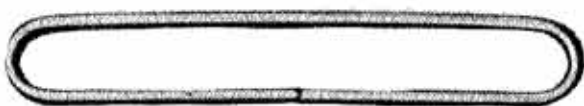

#1212-(3x5/16x.090)



#1322-(2-1/2x1x.220)

PHILIP MACHINE COMPANY

184 WOONASQUATUCKET AVENUE NORTH PROVIDENCE, RHODE ISLAND 02911

“D” RINGS

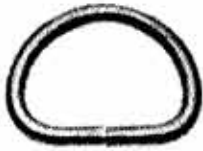

1330 - (3/4 x 9/16 x .120)



1402 - (5/8 x 1/2 x .162)



1456 - (1 x 3/4 x .102 FANCY)

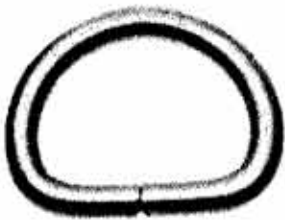

1328 - (1 x 3/4 x .190)



1357 - (1 x 3/4 x .120)



1410 - (1 1/8 x 11/16 x .102)



1452 - (1 1/4 x 1 x .148)



1457 - (3/4 x 5/8 x .102)



1332 - (1 x 13/16 x .135)



1331 - (1 3/4 x 1 1/4 x .135)

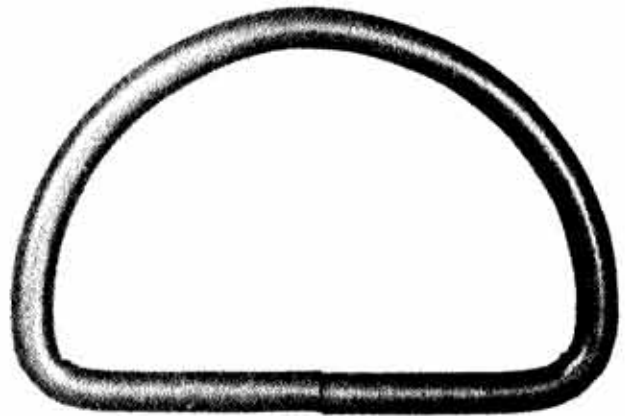

1468 - (2 1/2 x 1 11/16 x .220)

PHILIP MACHINE COMPANY

184 WOONASQUATUCKET AVENUE NORTH PROVIDENCE, RHODE ISLAND 02911

“O” RINGS



1424 - (1 1/4 x .190)



1508 - (1 1/4 x .229)



1515 - (1 1/2 x .177)

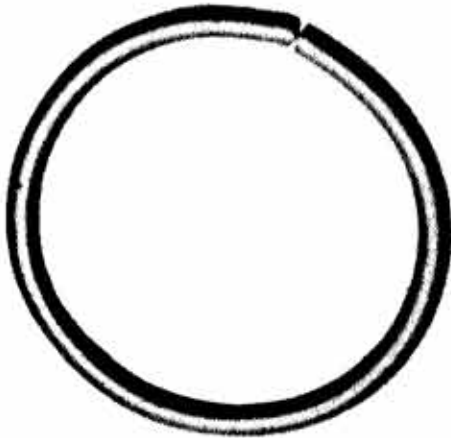

1360 - (2 x .177)

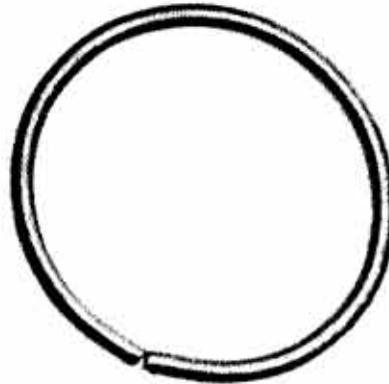

1449 - (1 3/4 x .128)

NOT
SHOWN

1539 - (2 1/2 x .148)



1526 - (2 x .128)

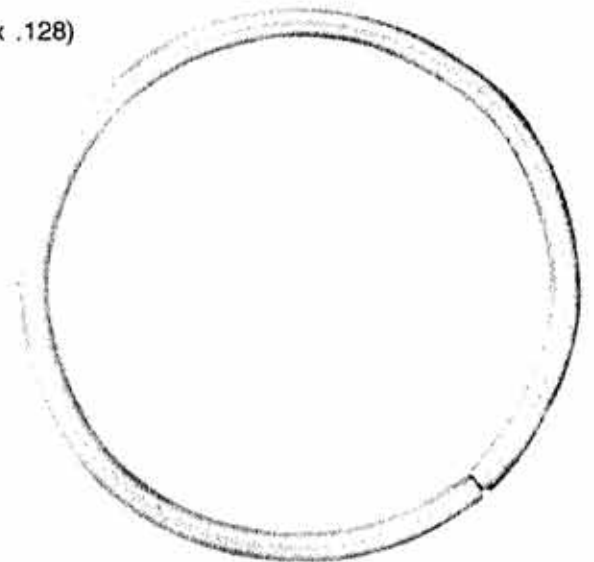

1525 - (3 x .177)

PHILIP MACHINE COMPANY

184 WOONASQUATUCKET AVENUE NORTH PROVIDENCE, RHODE ISLAND 02911

SWING BARS

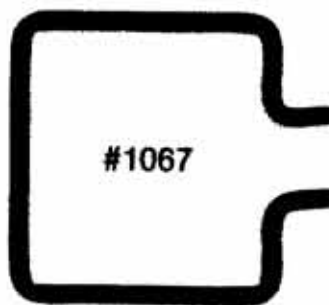
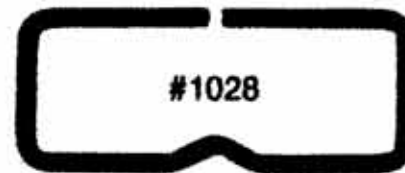
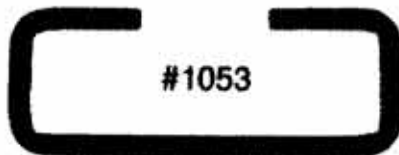
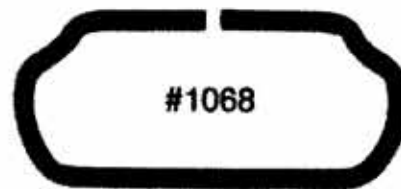
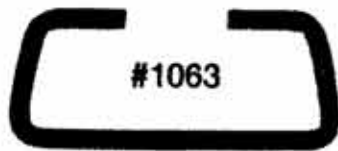
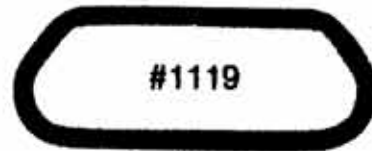
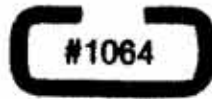

*ACTUAL SIZES SHOWN
*OPENING VARIABLE BY SPECIAL ORDER

PHILIP MACHINE COMPANY

184 WOONASQUATUCKET AVENUE NORTH PROVIDENCE, RHODE ISLAND 02911

WIRE RINGS



#1199-(3/8x3/8x.060)



#1260-(1/6x13/16x.177)



#1209-(1-1/4x1x.090)

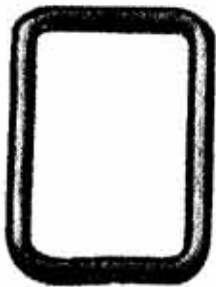

#1336-(13/16x1-1/8x.135)



#1295-(3/4x.102)

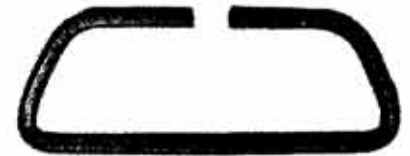

#1276-(1-3/4x9/16x.102)



#1208-(1-1/4x1/2x.114)



#1278-(1/3x.128)



#1257-(1-1/4x1-1/2x.114)



#1300-(1/6x1-1/4x.220)

PHILIP MACHINE COMPANY

184 WOONASQUATUCKET AVENUE NORTH PROVIDENCE, RHODE ISLAND 02911

WIRE RINGS



1377 - (1/2 x 1/4 x .080)



1495 - (3/8 x 1/8 x .050)



1378 - (3/4 x 1/4 x .080)



1420 - (1 5/16 x 1/2 x .102)



1389 - (3/4 x .148)



1499 - (1 1/8 x 1/4 x .135)

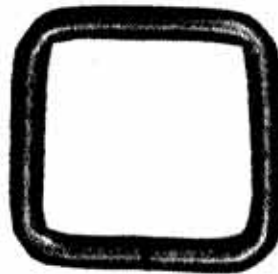

1513 - (1 x 1 x .177)



1394 - (1 x .148)



1370 - (1 1/8 x 9/16 x .135)

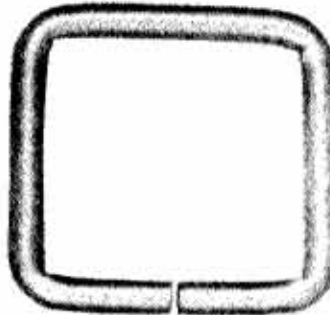

1511 - (1 5/16 x 1 3/16 x .190)



1392 - (1 1/4 x .162)



1455 - (2 1/4 x 5/16 x .090)

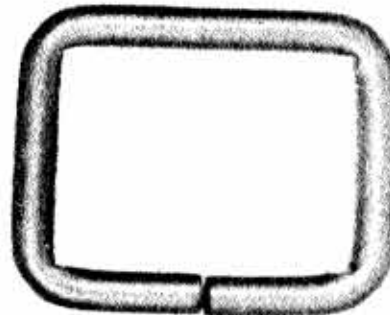

1512 - (1 1/2 x 1 1/8 x .220)



1390 - (1 1/2 x .177)

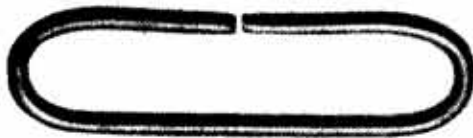

1406 - (2 1/4 x 1/2 x .128)

PHILIP MACHINE COMPANY

184 WOONASQUATUCKET AVENUE NORTH PROVIDENCE, RHODE ISLAND 02911

RECTANGLES



1484 - (3/4 x 3/8 x .102)



1327 - (3/4 x 5/16 x .080)



1302 - (5/8 x 3/16 x .060)



1361 - (5/8 x 5/16 x .080)

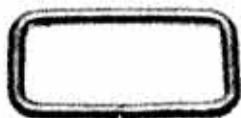

1447 - (1 x 3/8 x .102)

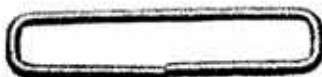

1461 - (1 1/2 x 3/16 x .080)



1503 - (1 3/8 x 3/16 x .080)

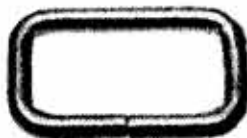

1464 - (1 x 1/2 x .148)



1403 - (1 x 3/4 x .135)



1489 - (1 x 3/8 x .102)

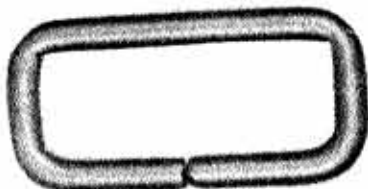

1502 - (1 1/2 x 1/2 x .177)

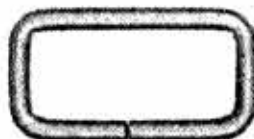

1501 - (1 1/16 x 7/16 x .120)

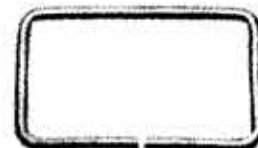

1440 - (1 1/8 x 5/8 x .080)

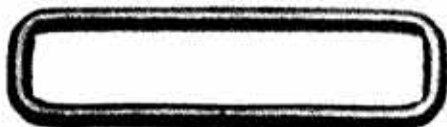

1429 - (2 x 3/8 x .135)

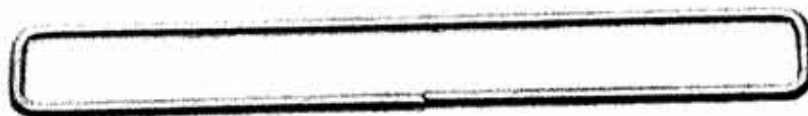

1334 - (4 x 3/8 x .102)

PHILIP MACHINE COMPANY

18 WINDMILL AVENUE, NORTH PROVIDENCE, RHODE ISLAND 02911

RECTANGLES



#1085-(.260 x .115 x .050)



#1024-(7/16 x 5/32 x 080)



#1039-(1/2 x 5/16 x 080)



#1020-(13/32 x 1/4 x 080)



#1015- x (3/8 x 5/32 x 080)

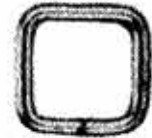

#1135-(1/2 x 1/2 x .102)



#1059-(1/4 x 13/32 x 080)



#1041-(1/2 x 1/8 x 070)



#1057-(3/4 x 1/4 x 080)



#1147-(7/16 x 7/16 x 060)



#1021-(1/2 x 1/4 x 080)



#1042-(3/4 x 3/8 x 080)



#1040-(11/16 x 3/8 x 080)



#1105-(5/8 x 1/4 x 080)



#1011-(1 x 3/16 x 070)



#1152-(3/4 x 3/8 x .102)



#1004-(5/8 x 3/8 x .080)

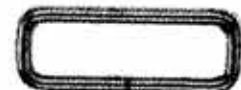

#1029-(1 x 9/32 x 080)

PHILIP MACHINE COMPANY

184 WOONASQUATUCKET AVENUE NORTH PROVIDENCE, RHODE ISLAND 02911

RECTANGLES



#1148-(5/8 x 5/8 x .128)



#1019-(1-1/32 x 17/32 x .102)



#1032-(3/4 x 5/8 x .102)



#1170-(1 x 3/8 x .080)



#1122-(3/4 x 5/8 x .114)

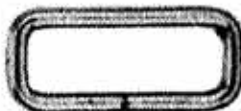

#1061-(1 x 5/16 x .114)



#1194-(15/16 x 3/4 x .128)

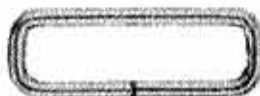

#1128-(1-1/8 x 1/4 x 102)

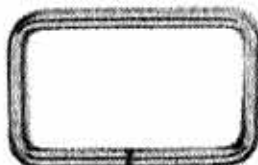

#1127-(1-1/8 x 5/8 x .102)



#1208 (1 1/4 x 1/2 x .114)

PHILIP MACHINE COMPANY

184 WOONASQUATUCKET AVENUE NORTH PROVIDENCE, RHODE ISLAND 02911

KEEPERS



#1117 - (1.10 x .285 x 1/2 x .050)

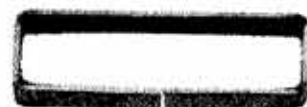

#1062 - (1 1/2 x 3/8 x 3/8 x .032)



#1138 - (1 3/4 x 3/8 x 11/16 x .032)



#1140 - (2 x 1/2 x 3/8 x .032)



#1124 - (2 x 3/8 x 1/2 x .050)

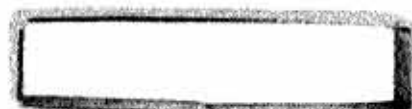

#1118 - (2 x 3/8 x 3/8 x .032)



#1144 - (2 1/2 x 3/8 x 1/2 x .050)

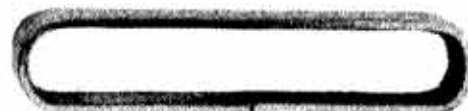

#1125 - (2 1/4 x 3/8 x 1/2 x .050)

#1126 - (2 x 3/8 x 1/2 x .050)

PHILIP MACHINE COMPANY

184 WOONASQUATUCKET AVENUE NORTH PROVIDENCE, RHODE ISLAND 02911

KEEPERS



#1055
(11/16 x 5/16 x 1/4 x 045)
Fancy Wire



#1137
(25/32 x 5/16 x 1/4 x 045)
Fancy Wire

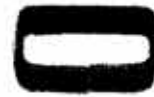

#1123
(11/16 x 5/16 x 1/4 x 032)



#1151
(1 1/4 x 5/16 x 1/4 x 045)



#1150
(3/4 x 5/16 x 3/8 x 032)



#1143
(1 x 5/16 x 3/8 x 032)

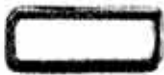

#1108
(3/4 x 1/4 x 3/16 x 032)



#1200
(3/4 x 3/8)
Half Round Wire



#1167
(1 x 1/2 x 3/8 x 040)
For Swaging

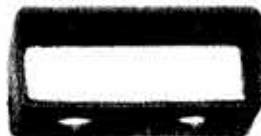

#1168
(1 1/4 x 1/2 x 1/2 x 040)
For Swaging

PHILIP MACHINE COMPANY

184 WOONASQUATUCKET AVENUE NORTH PROVIDENCE, RHODE ISLAND 02911

TUCK LOOPS



#1273



#1136



#1210



#1270



#1263



#1251



#1262



#1301



#1107



#1227



#1339



#1340

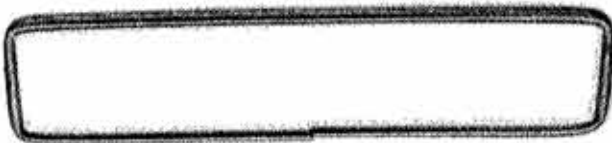

#1290



#1272



#1219



#1297



#1271

PHILIP MACHINE COMPANY

184 WOONASQUATUCKET AVENUE NORTH PROVIDENCE, RHODE ISLAND 02911

SPECIALTY ITEMS



#1030-(3x.090)



#1229-(1-3/4x.080)



#1321



#1233-(1-1/2"x.080)

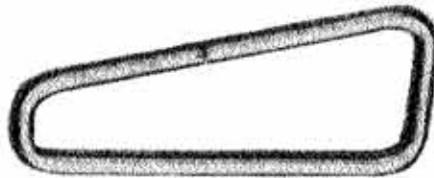

#1228



#1050



#1027-(3/4x.090)



#1076-(1x.090)



#1326-(1x.080)

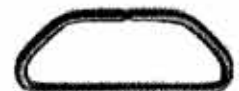

#1026-(1x.090)

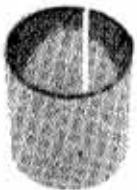

#1315-(3/4" Large Tube)



#1323-(3/4" Open Tube)



#1254-(3/4" Tube)



#1259-(1" Belt Tip)

PHILIP MACHINE COMPANY

184 WOONASQUATUCKET AVENUE NORTH PROVIDENCE, RHODE ISLAND 02911

SPECIALTY ITEMS



#1134



#1059



#1045



#1100



#1048



#1102



#1079



#1337



#1086

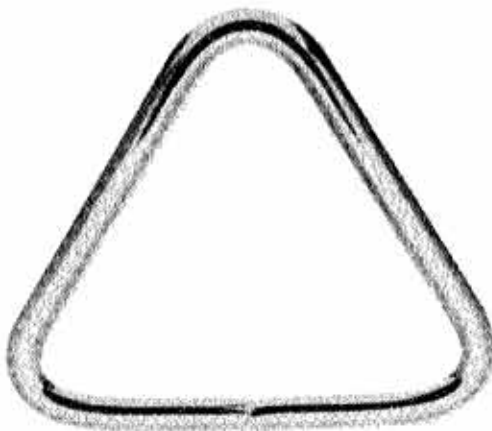

#1316-(2x.220)



| SNAP HOOKS #S | SIZE |
|---------------|--------|
| 1223 | 2" |
| 1224 | 1-1/2" |
| 1225 | 1" |

PHILIP MACHINE COMPANY

184 WOONASQUATUCKET AVENUE NORTH PROVIDENCE, RHODE ISLAND 02911

TONGUES/PRONGS

In an effort to eliminate confusion on orders PMC has attempted to codify all tongues. PMC tongue styles will start with a group of letters, separated by a hyphen, and followed by three numbers (i.e. J-E162, FF-EE200). The letter or group of letters to the left of the hyphen will signify the type of wire or stock being formed and its dimensions. The letter or group of letters after the hyphen will represent the style or shape of the tongue. The remaining three numbers will represent the length of the tongue in inches (i.e. J-E162 = 1.620 or 1-5/8"). Note that all tongues are measured from the middle of the tail (A), which wraps around the bridge, to the tongue tip (B).



J-B162

- J = Stock .120 x .060 half round
B = Tongue Style/Shape
162 = 1.620 or 1-5/8"



J-E162

- J = Stock .120 x .060 half round
E = Tongue Style/Shape
162 = 1.620 or 1-5/8"



K-H212

- K = Stock 1/4" x .047 half oval
H = Tongue Style/Shape
212 = 2.12 or 2-1/8"

PHILIP MACHINE COMPANY

184 WOONASQUATUCKET AVENUE NORTH PROVIDENCE, RHODE ISLAND 02911

ROUND WIRE



D-F SERIES: - Wire Diameter .080/14 gauge
- sizes available 13/16" - 1-1/2"
- rolls around .110 bridge



E-F SERIES: - wire diameter .090/13 gauge
- sizes available 13/16" - 1-1/2"
- rolls around .110 bridge



F-G SERIES: - wire diameter .102/12 gauge
- sizes available 13/16" - 1-1/2"
- rolls around .150 bridge



G-A SERIES: - wire diameter .114/11 gauge
- sizes available 1-3/8" - 3"
- rolls around .187 bridge



H-L SERIES: - wire diameter .128/10 gauge
- sizes available 1-3/8" - 3-1/2"
- rolls around .250 bridge

PHILIP MACHINE COMPANY

184 WOONASQUATUCKET AVENUE NORTH PROVIDENCE, RHODE ISLAND 02911

HALF OVAL/FLAT



K-H SERIES: - Stock 1/4" x .047 half oval
- sizes available 1-1/2" - 3"
- rolls around .187 bridge



Y-J SERIES: - Stock 1/4" x .040 flat
- sizes available 1-1/4" - 3"
- rolls around .312 bridge



W-K SERIES: - Stock 1/2" x .040 flat
- sizes available 1-1/2" - 2-1/2"
- rolls around .375 bridge



Z-B SERIES: - Stock 3/16" x .037 flat
- sizes available 1-1/4" - 3"
- rolls around .187 bridge



X-J SERIES: Stock 3/8" x .032 flat
- sizes available 1-1/4" - 3"
- rolls around .312 bidge



K-B SERIES: Stock 1/4" x .047 half oval
- sizes available 1-1/4" - 3"
- rolls around .187 bridge

PHILIP MACHINE COMPANY

184 WOONASQUATUCKET AVENUE NORTH PROVIDENCE, RHODE ISLAND 02911

HALF ROUND



J-A SERIES: - wire .120 x .060 half round
- sizes available 1-3/8" - 3"
- rolls around .150 bridge



J-F SERIES: - wire .120 x .060 half round
- sizes available 13/16" - 1-1/2"
- rolls around .110 bridge



J-B SERIES: - wire .120 x .060 half round
- sizes available 1-1/4" - 3"
- rolls around .187 bridge



J-D SERIES: - wire .120 x .060 half round
- sizes available 1-1/4" x 2-1/2"
- rolls around .250 bridge



J-K SERIES: - wire .120 x .060 half round
- sizes available 1-1/4" - 2-1/2"
- rolls around .375 bridge



J-E SERIES: - wire .120 x .060 half round
- sizes available 1-1/4" - 2-1/2"
- rolls around .312 bridge

PHILIP MACHINE COMPANY

184 WOONASQUATUCKET AVENUE NORTH PROVIDENCE, RHODE ISLAND 02911

STRETCH BUCKLES

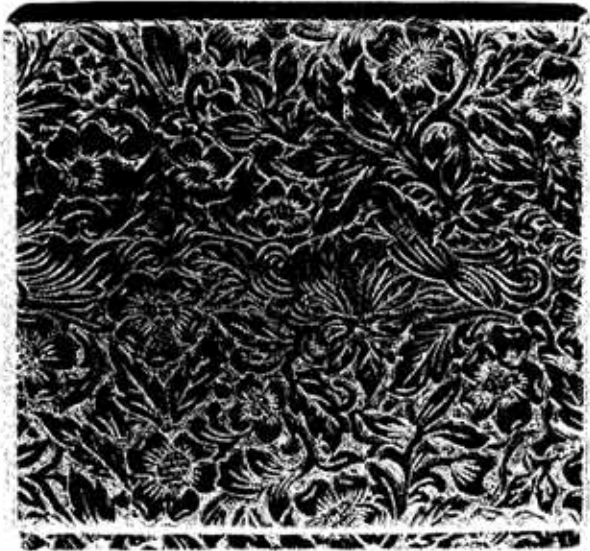

9070 - FLORAL SQUARE



9078 - CIRCLE WITH RIM
FOR EPOXY



9075 - SECTIONED OVAL
FOR EPOXY

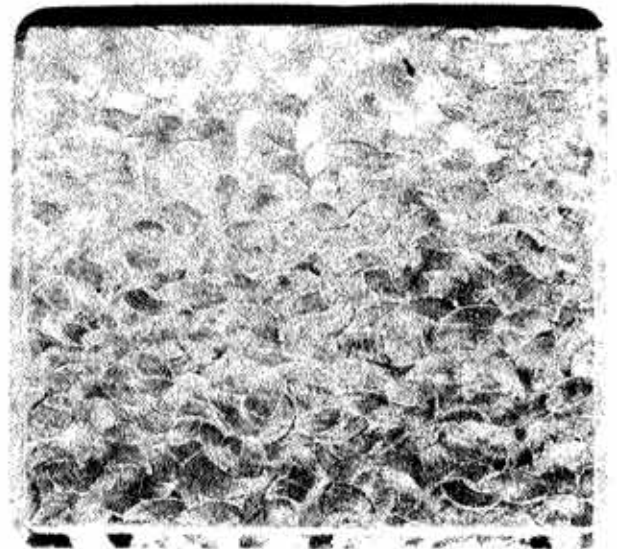

9069 - STUCCO SQUARE

STRETCH BUCKLES

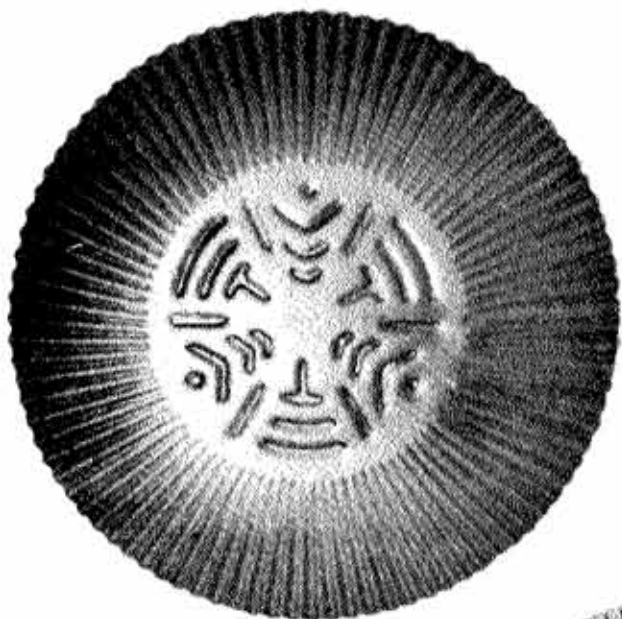

9062 - RADIAL CIRCLE

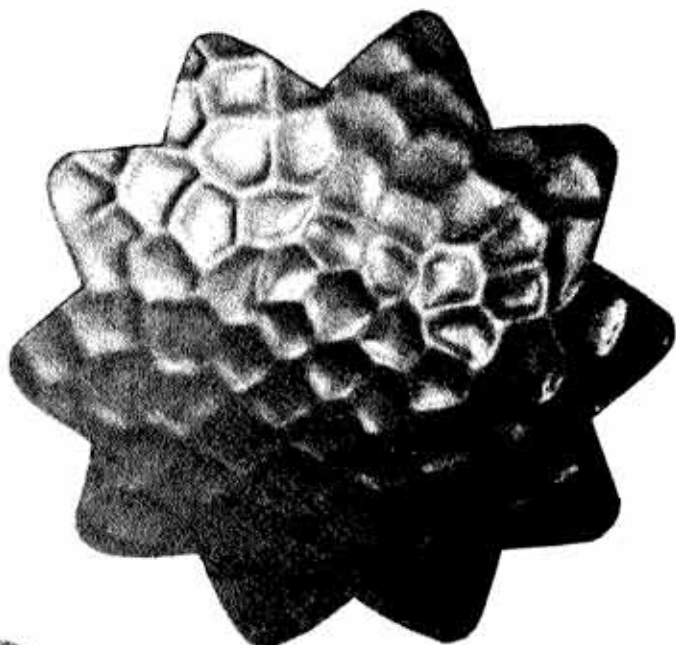

9058 - HAMMERED STAR

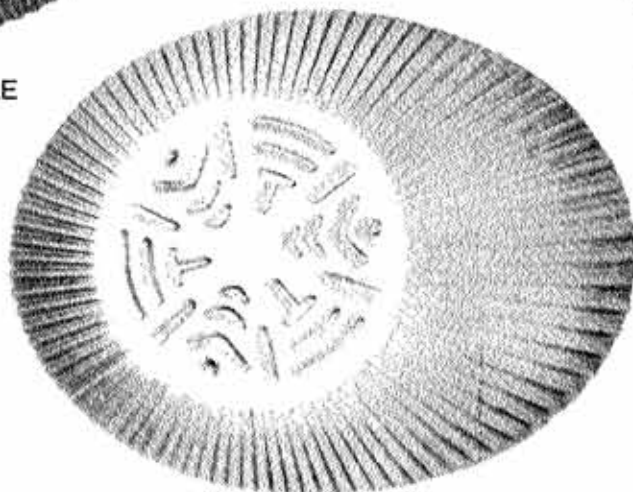

9063 - RADIAL OVAL - OFF CENTER

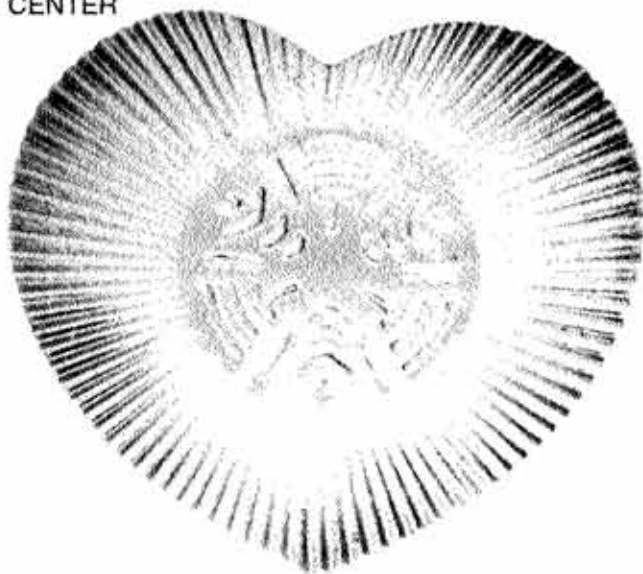
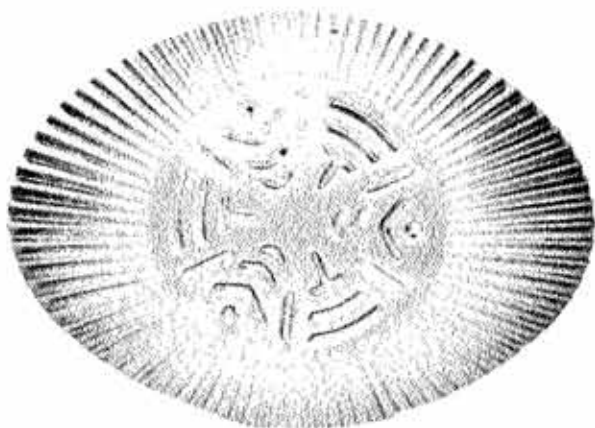

STRETCH BUCKLES

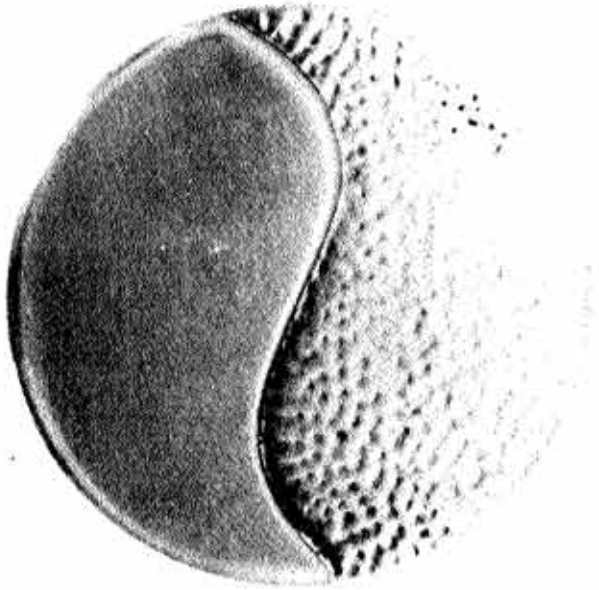

9024 - YING YANG

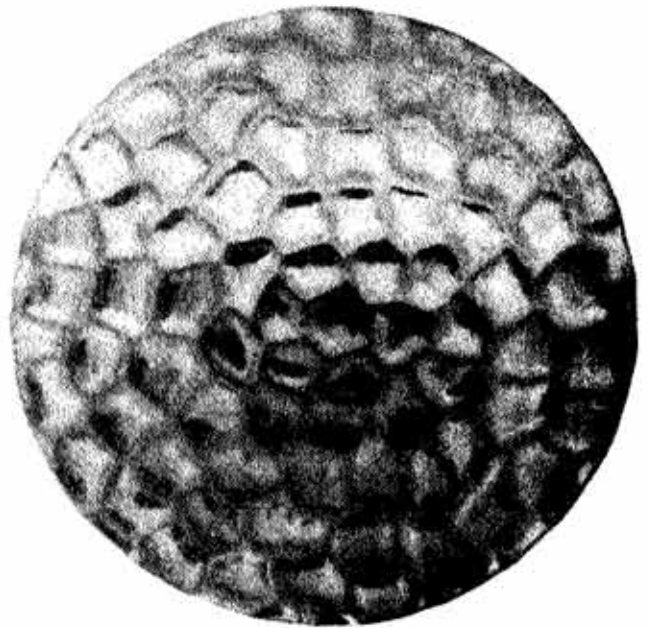

9022 - HAMMERED CIRCLE



9044 - STARBURST OVAL

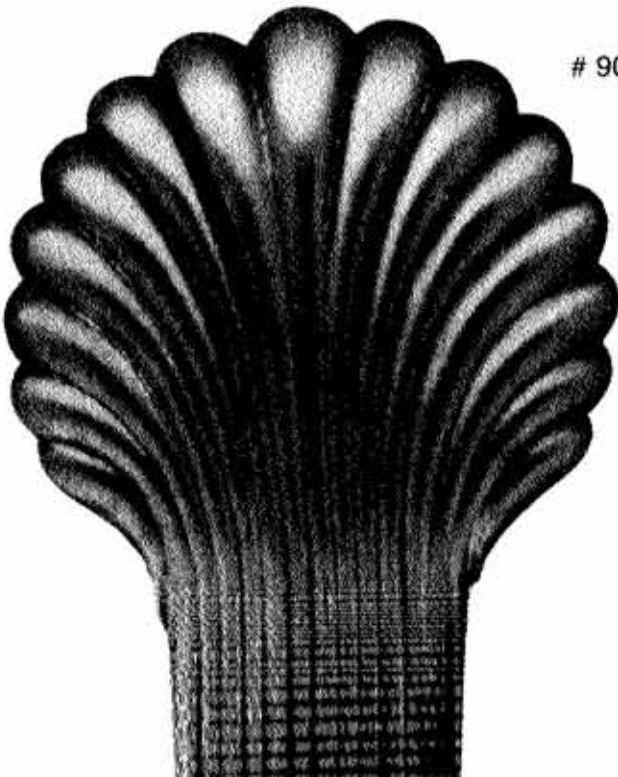

STRETCH BUCKLES

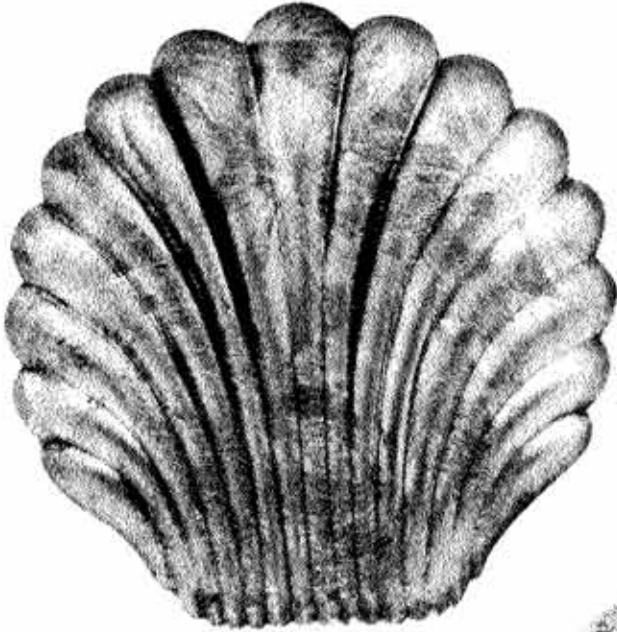

9035 - STARBURST SEASHELL

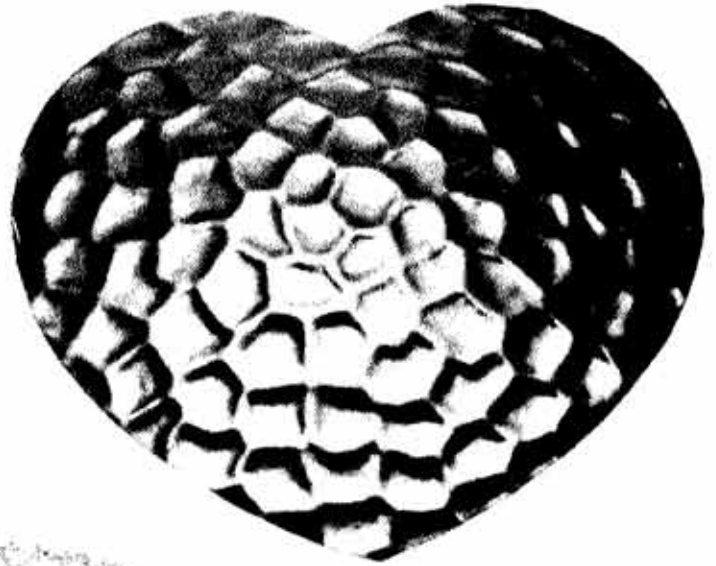

9047 - HAMMERED HEART



9048 - FLORAL CIRCLE



9021 - HAMMERED LEAF

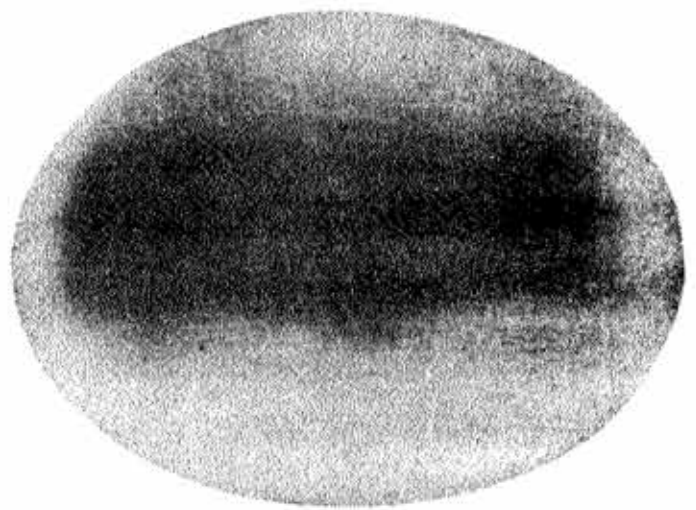

9040 - SMOOTH OVAL

WIRE BUCKLES

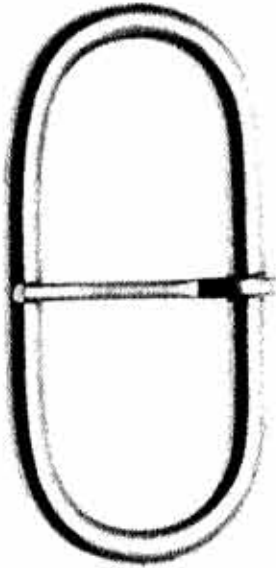

9016 - 2 1/2"

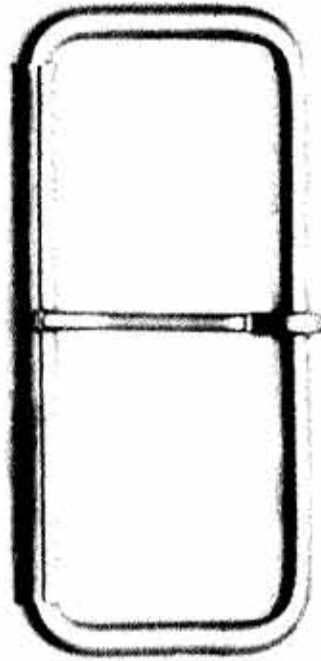

9006 - 3" ROLLER

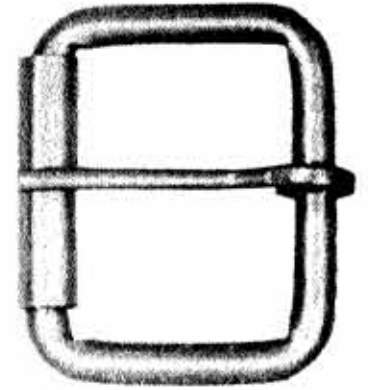

9066 - 1 1/2" ROLLER

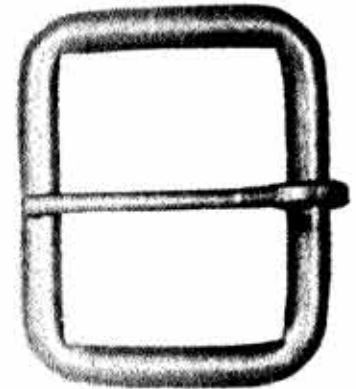

9051 - 1 1/2"

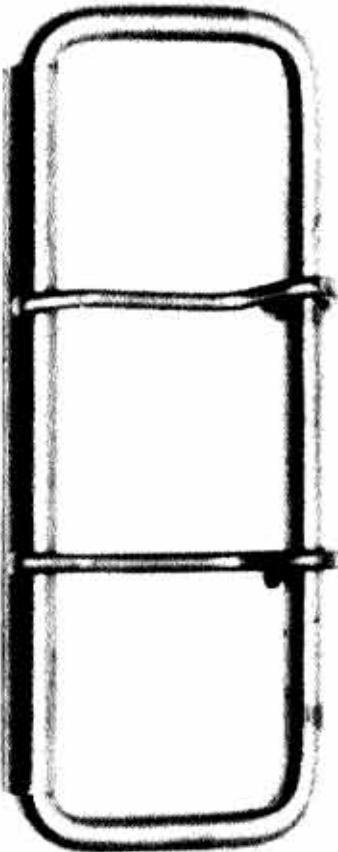

9003 - 4" ROLLER - 2 TONGUES



9032 - 3" ROLLER — NO TONGUE



9001 - 1 1/4"

"ACTUAL SIZE"

PHILIP MACHINE COMPANY

184 WOONASQUATUCKET AVENUE NORTH PROVIDENCE, RHODE ISLAND 02911

WIRE BUCKLES

1" DEE & TIP

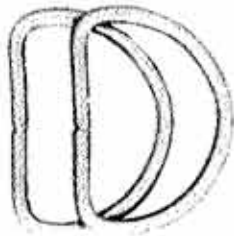

1357's



1259



9017 - 1" SLIDER

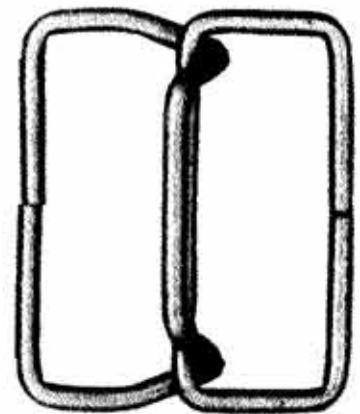

9005 - 2" INTERLOCK

1 1/2" DEE & TIP

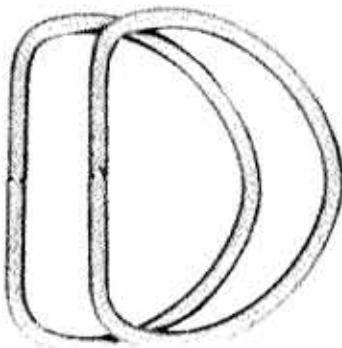

1294's



1355

2" DEE & TIP

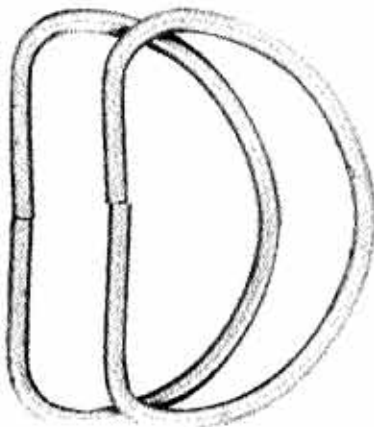

1160's



1349

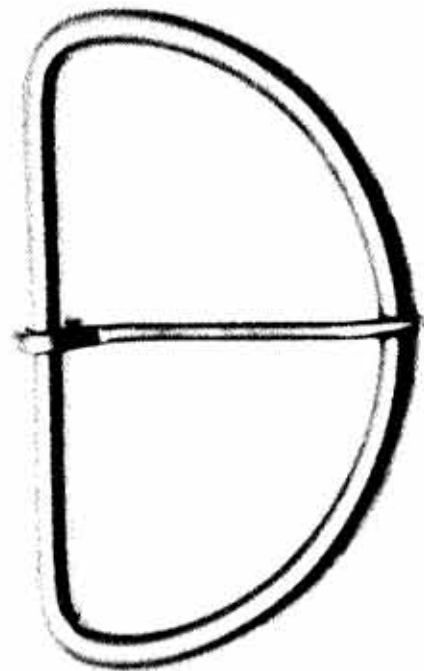

9004 - 3" DEE RING

PHILIP MACHINE COMPANY

124 WOONASQUATUCKET AVENUE NORTH PROVIDENCE, RHODE ISLAND 02911



1527



1528



1529



1531



1533



1537

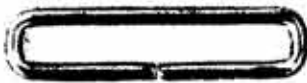

1538

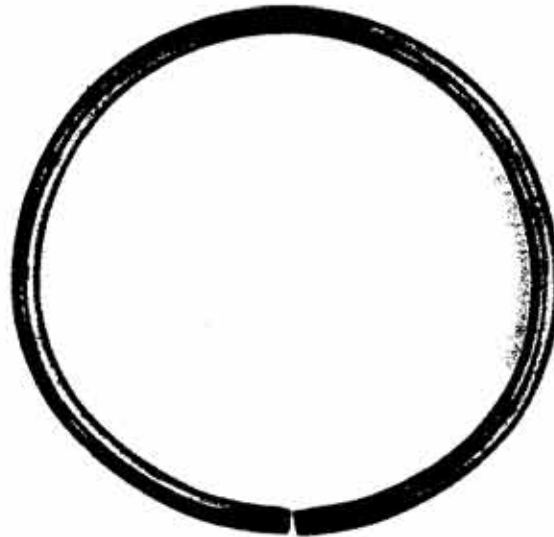

1539



1543



1544



1545

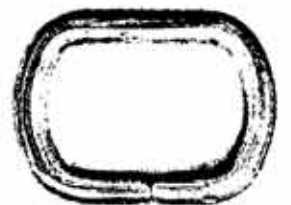

1546



1547

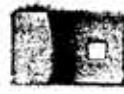

1548



1549



1550



1551



1552



1574



1575

1583



1585



1590



1591



1592



1593

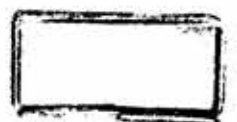

1601



1622

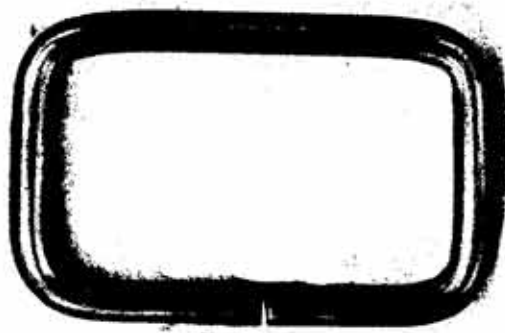

1635



1638



1640

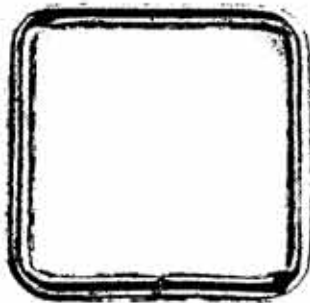

1641

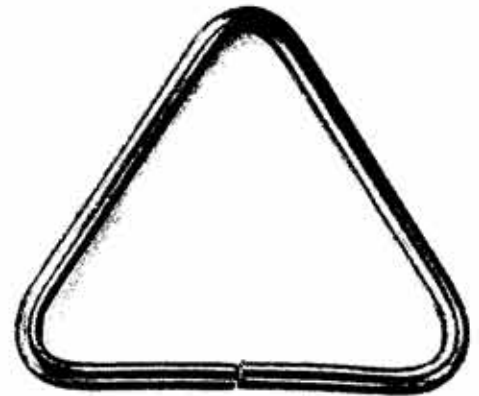

1644



1645

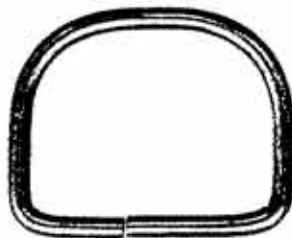

1646



1649



1650



1651

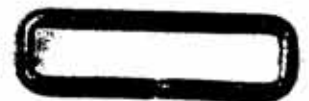

1652



1602



1603



1604



1606

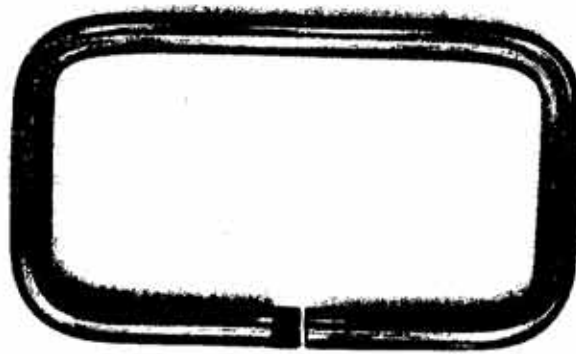

1607



1608



1610



1612



1613



1614



1615



1621

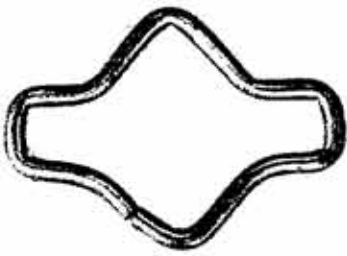

1673

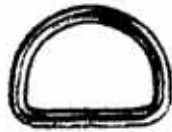

1676



1678



1679



1680



1681



1682



1684



1686



1692



1693



1695



1697

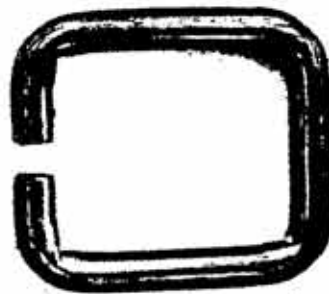

1698



1703



1704

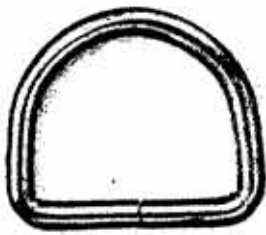

1656



1657



1659



1660

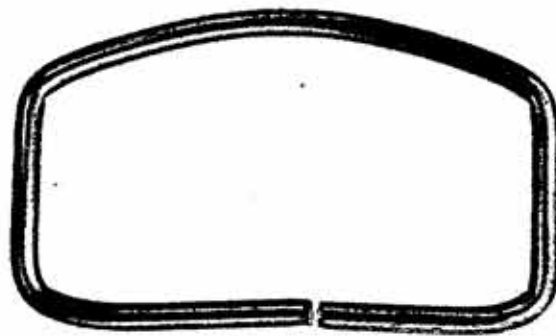

1661



1662

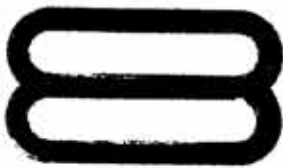

1663



1664



1666



1669



1670



1671



1740



1741

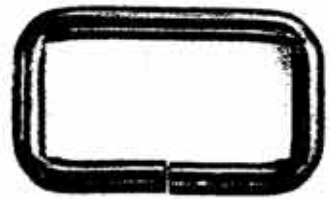

1743



1764



1766



1767



1777



1778



1779

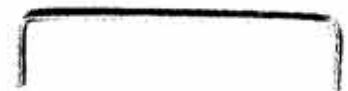

1782



1706



1707



1709



1710



1712



1713



1714



1715



1719



1723

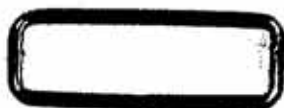

1724



1725



1727

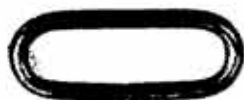

1728



1729



1733



1735



1807

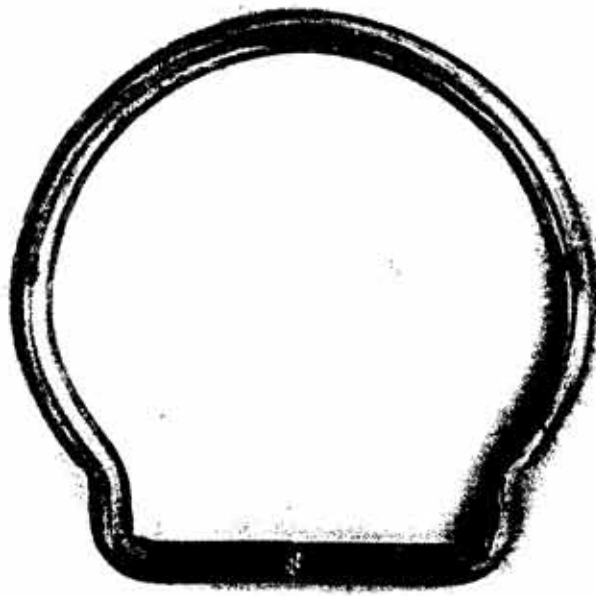

1808

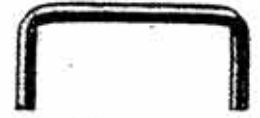

1810

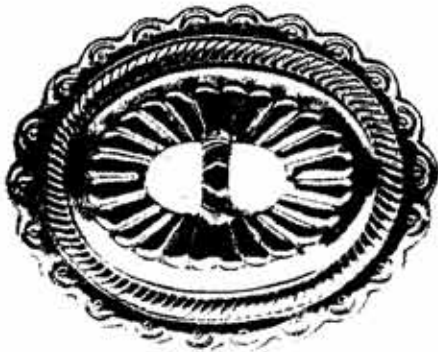

1812



1813



1814



1815

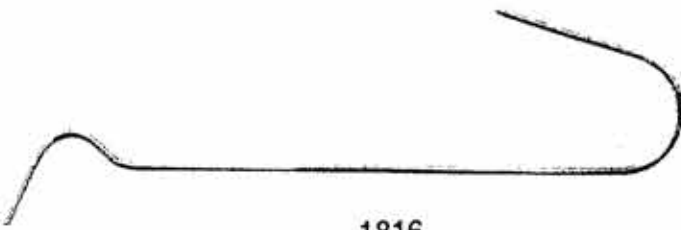

1816



1817



1818

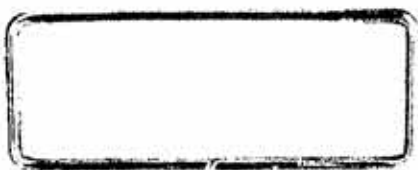

1820



1833



1836

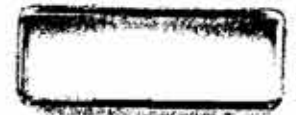

1837



1784



1785

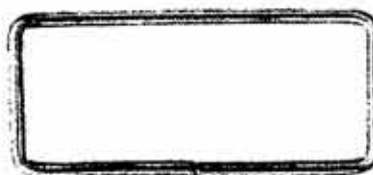

1787



1788

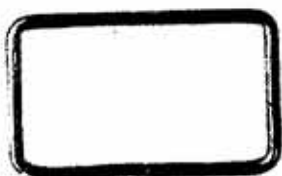

1789



1790



1792



1793

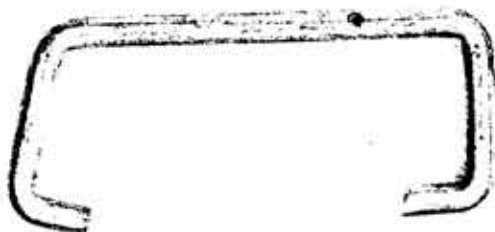

1794



1796



1797



1801



1802



1803

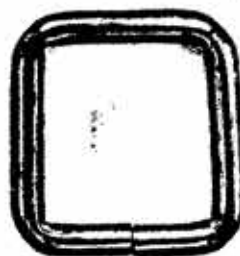

1804



1805



1806



1885



1886



1887



1888



1889



1891

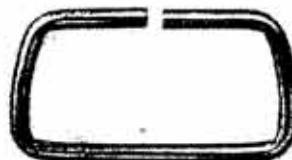

1892



1893



1894



1895



1896



1897



1898



1899



1900



1901



1902



1932



1933



1934



1935

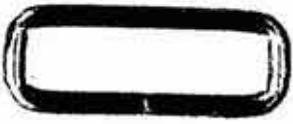

1936



1937



1938



1939



1940



1942



1943

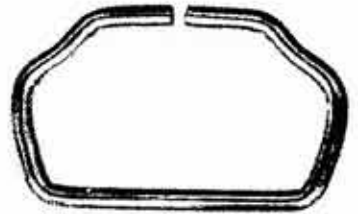

1944



1945



1946



1947



1948



1949

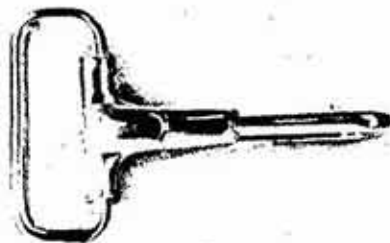

1951



1952

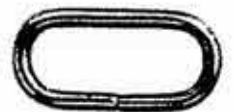

1956



1839



1840

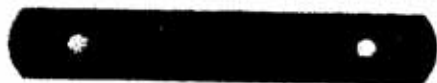

1841

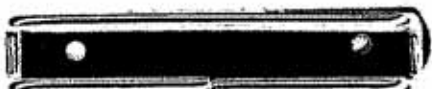

1842



1847



1848



1849



1850



1854

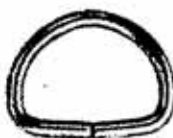

1858



1874



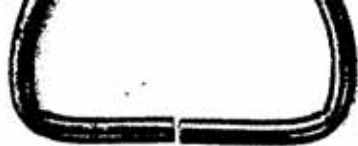

1876



1877

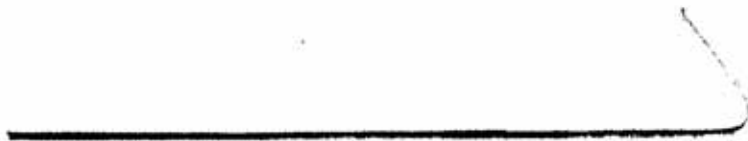

1884

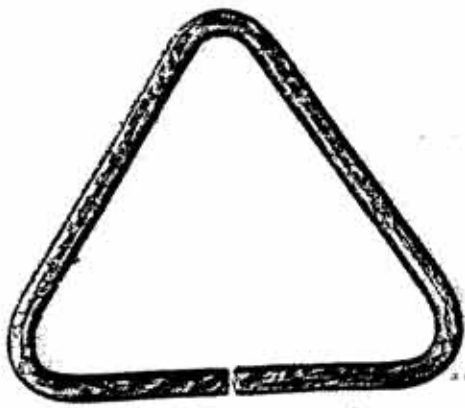

1977



1978



1979



1980



1982



1983



1984



1990



1991



1992



1994

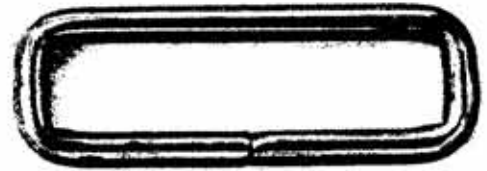

1997



1998



1999



2000



2006

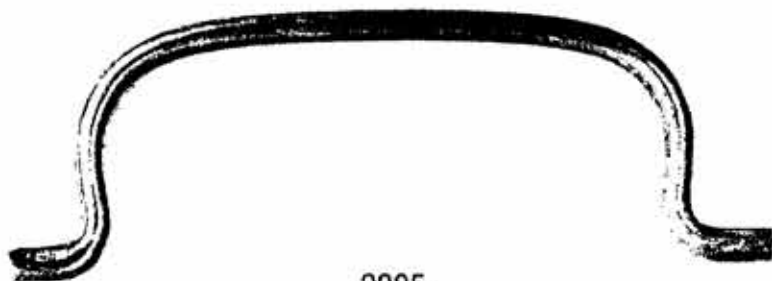

2005

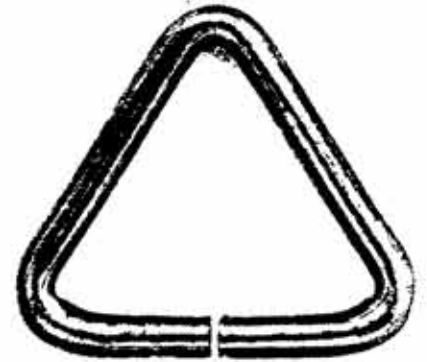

2007



1907



1908



1909



1910



1913

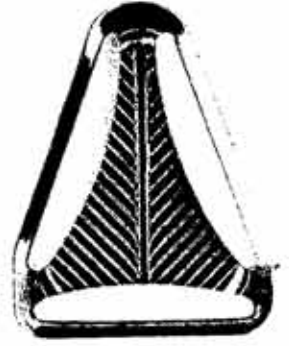

1914



1915

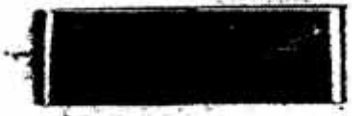

1917



1918



1919



1920



1921



1922

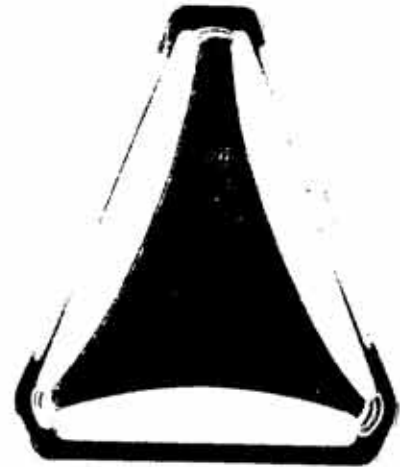

1924

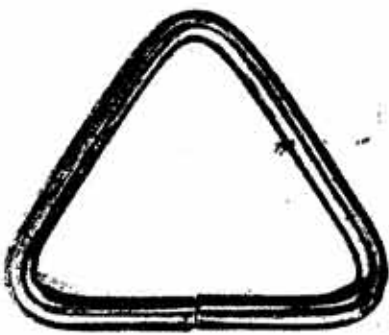

1925



1926



1927



1928

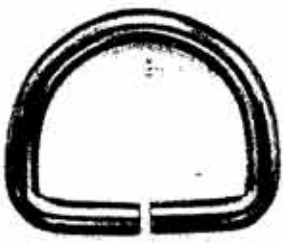

1957



1958



1959



1960



1961



1962



1966

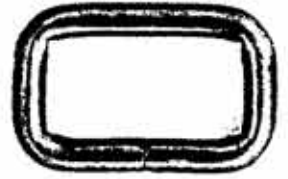

1967



1969

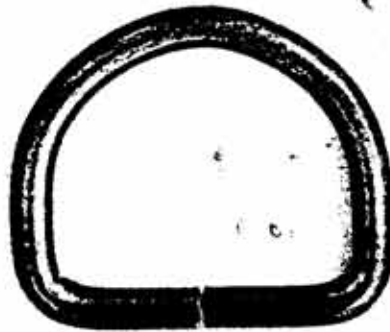

1970

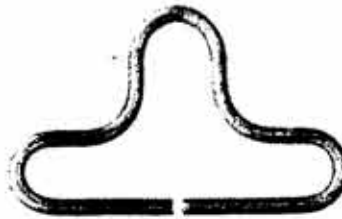

1971



1973



1974



1975

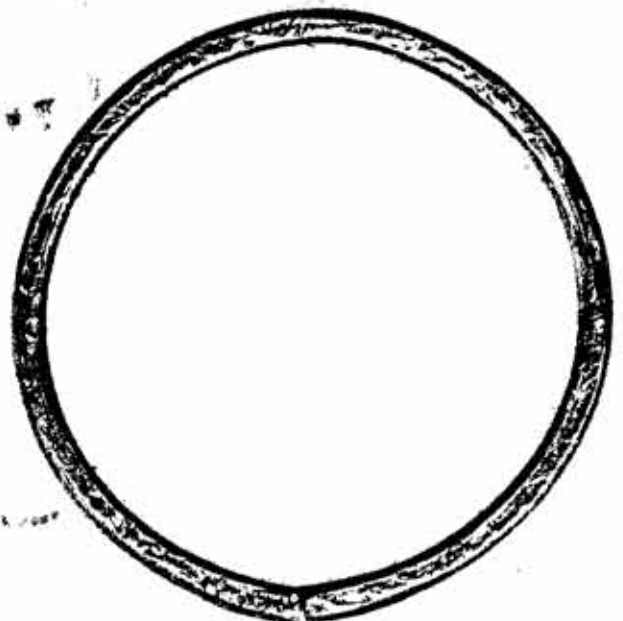

1976

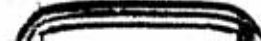



2008



2009

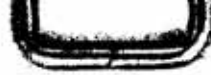

2011

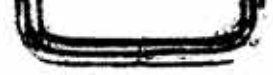

2012



2014



2015

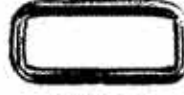

2016



2017



2018



2019



2022